

# NWC-1215-2 Series

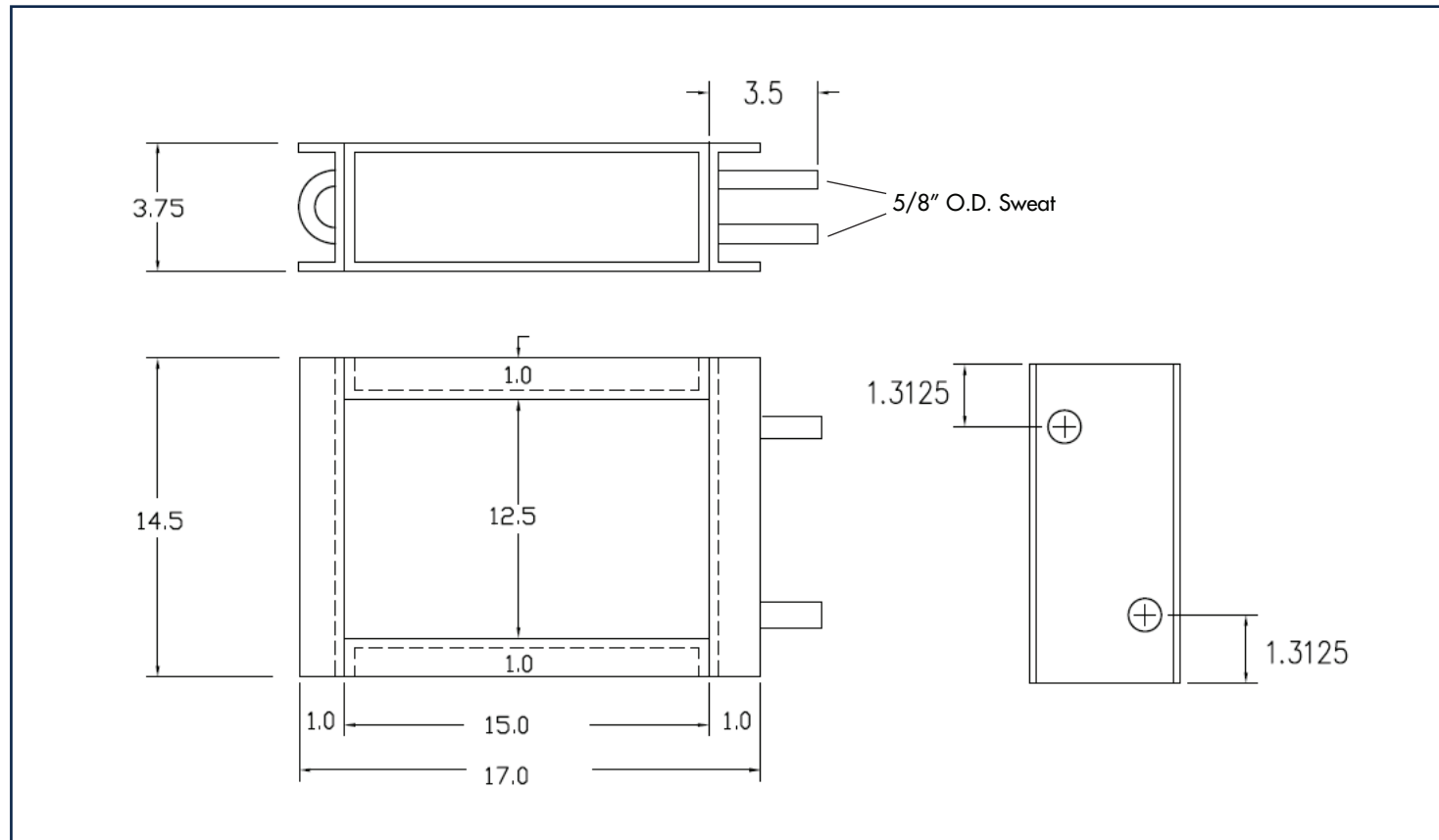

Model: NWC-1215-2				60°F Entering Air		
E.W.T.	GPM	P.D. FT	CFM	MBTUH	L.A.T. °F	L.W.T. °F
180°F	2	0.92	550	29.3	109.2	150
			775	34.2	100.8	144.9
			1000	37.99	95	141.2
	4	3.49	550	32.9	115.3	163.1
			775	39.46	106.9	159.8
			1000	44.56	101.1	157.2
	6	7.64	550	34.4	117.7	168.2
			775	41.58	109.5	165.8
			1000	47.3	103.6	163.8

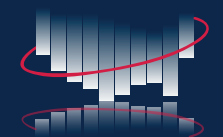

**NATIONWIDECOILS**

1-888-COIL-PRO  
www.nationwidecoils.com

# NWC-1215-3 Series

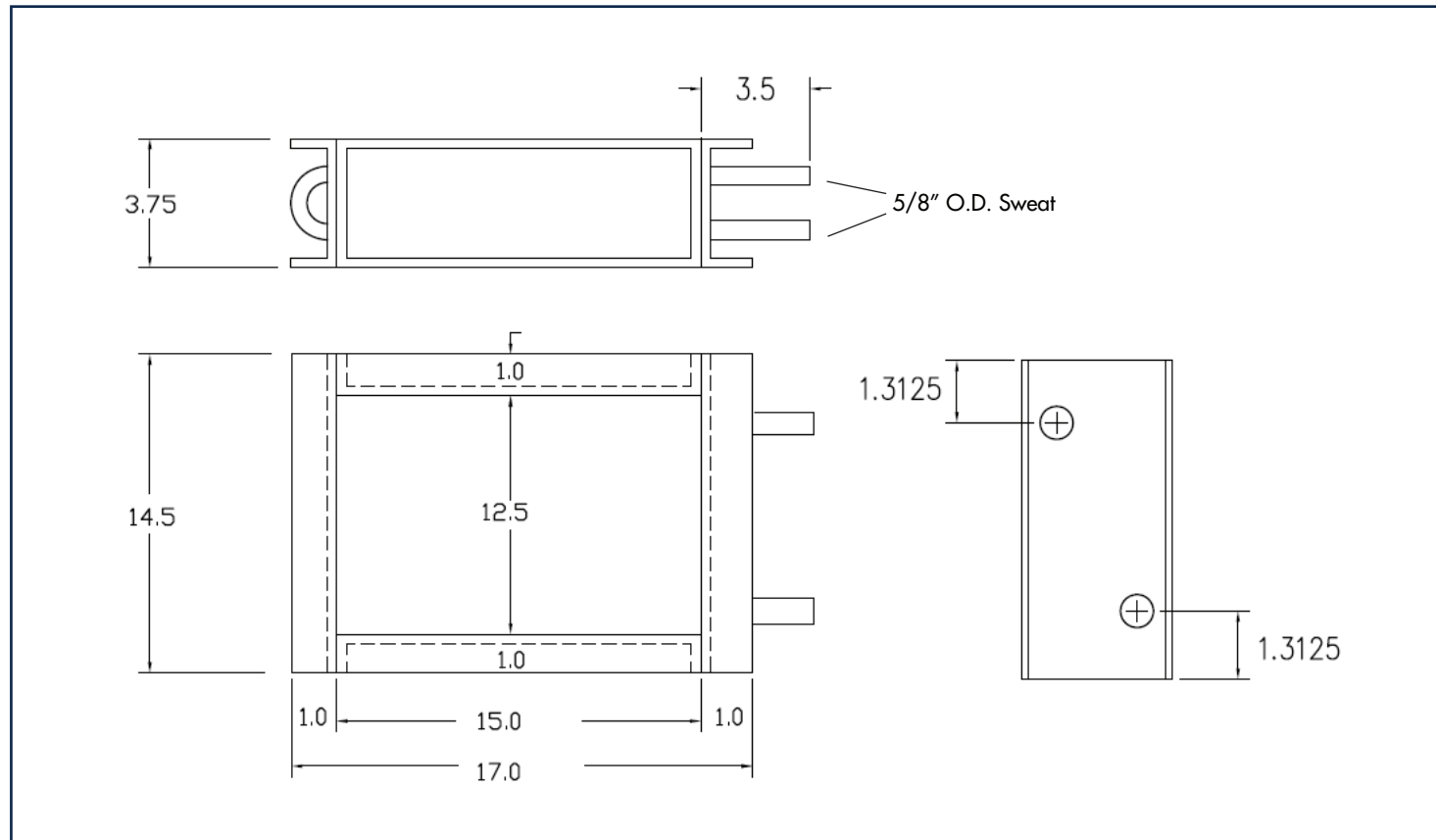

Model: NWC-1215-3				60°F Entering Air		
E.W.T.	GPM	P.D. FT	CFM	MBTUH	L.A.T. °F	L.W.T. °F
180°F	2	1.63	550	37.09	122.2	142.1
			775	43.39	111.6	135.7
			1000	47.96	104.2	131.1
	4	6.45	550	42	130.5	158.4
			775	50.9	120.6	153.9
			1000	57.76	113.3	150.4
	6	14.44	550	43.98	133.7	165
			775	53.93	124.2	161.6
			1000	61.86	117	158.9

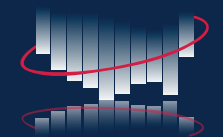

**NATIONWIDECOILS**

1-888-COIL-PRO  
www.nationwidecoils.com

# NWC-1218-2 Series

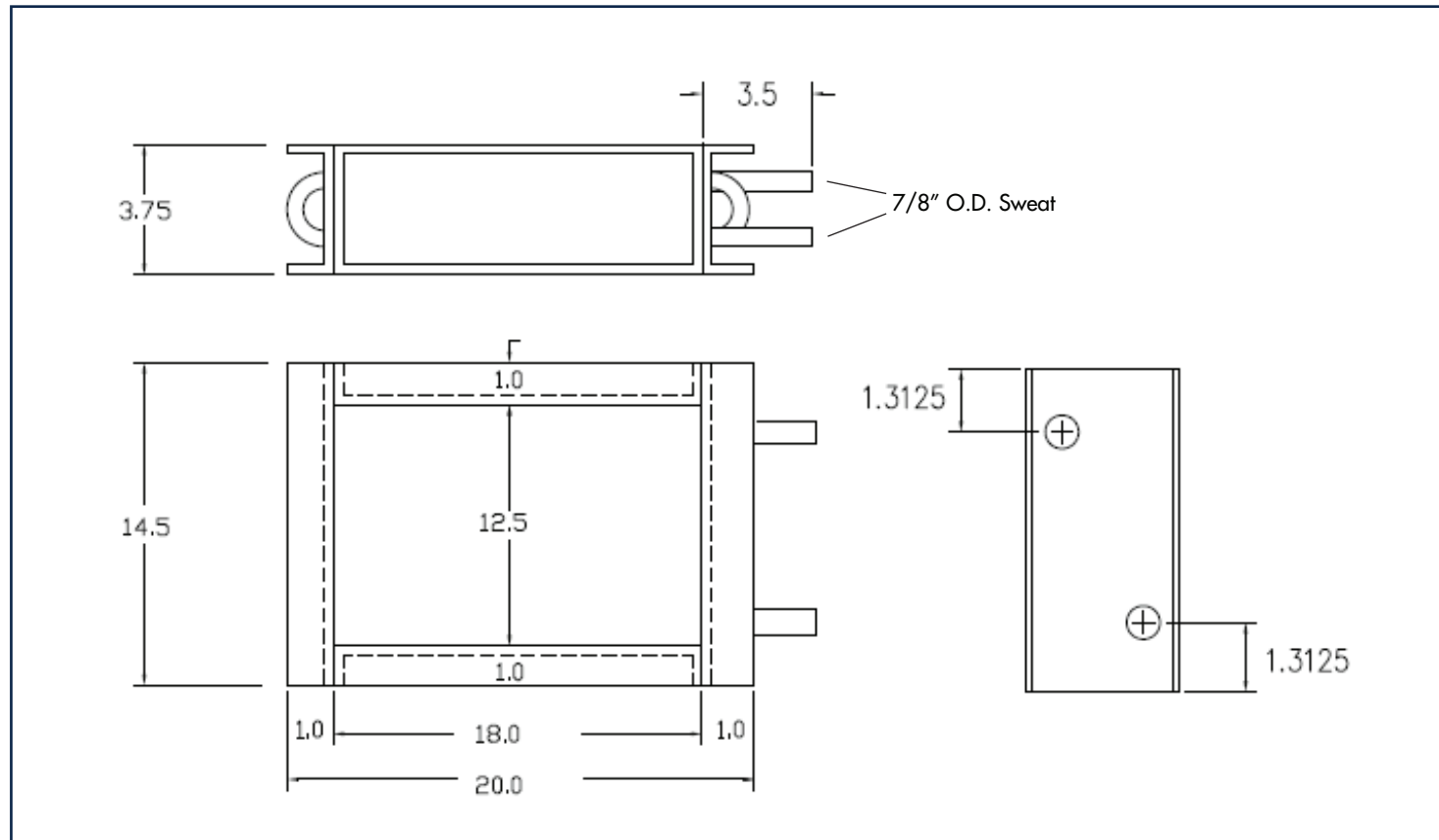

Model:NWC-1218-2				60°F Entering Air		
E.W.T.	GPM	P.D. FT	CFM	MBTUH	L.A.T. °F	L.W.T. °F
180°F	7.2	11.89	900	49.4	110.6	165.9
			1000	25.2	108.2	165.1
			1100	54.8	106	164.4

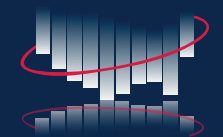

**NATIONWIDECOILS**

1-888-COIL-PRO  
www.nationwidecoils.com

# NWC-1520-2 Series

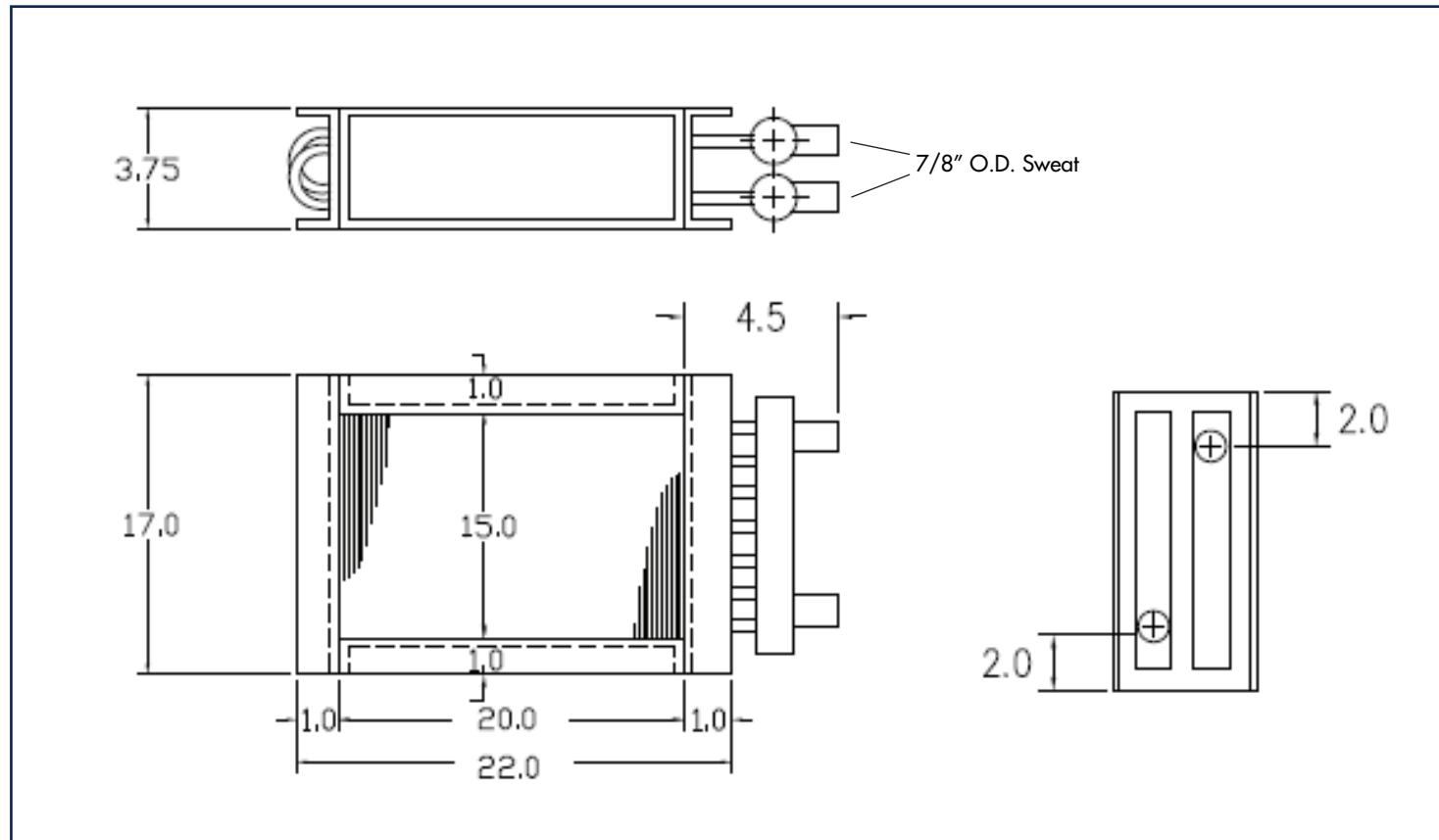

Model: NWC-1520-2				60°F Entering Air		
E.W.T.	GPM	P.D. FT	CFM	MBTUH	L.A.T. °F	L.W.T. °F
180°F	4	1.4	900	48.8	110	155
			1150	54.8	104	151.9
			1400	59.8	99.4	149.4
	8	5.5	900	54.2	115.6	166.1
			1150	61.8	109.6	164.1
			1400	68.3	105	162.5
	12	12.24	900	56.3	177.7	170.3
			1150	64.7	111.9	168.9
			1400	71.8	107.3	167.7

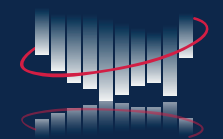

**NATIONWIDECOILS**

1-888-COIL-PRO  
www.nationwidecoils.com

# NWC-1520-3 Series

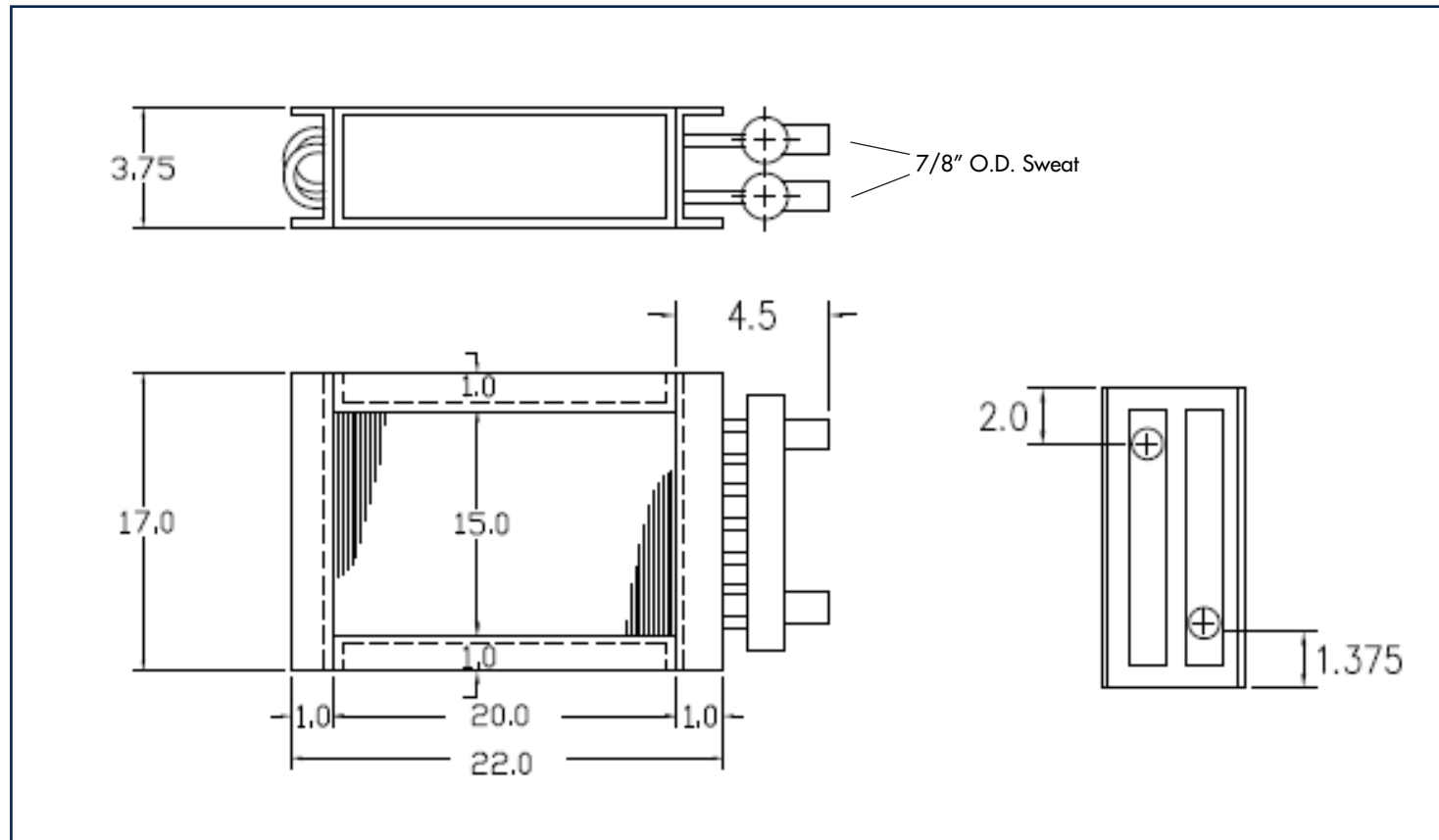

Model:NWC-1520-3				60°F Entering Air		
E.W.T.	GPM	P.D. FT	CFM	MBTUH	L.A.T. °F	L.W.T. °F
180°F	4	0.96	900	61.82	123.3	148.4
			1150	69.67	115.9	144.4
			1400	75.96	110	141.2
	8	3.77	900	69.21	130.9	162.2
			1150	79.68	123.9	159.6
			1400	88.47	118.3	157.3
	10	5.88	900	70.89	132.6	165.4
			1150	82.02	125.8	163.2
			1400	91.45	120.2	161.2

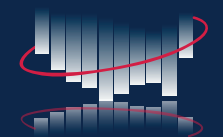

**NATIONWIDECOILS**

1-888-COIL-PRO  
www.nationwidecoils.com

# NWC-1724-2 Series

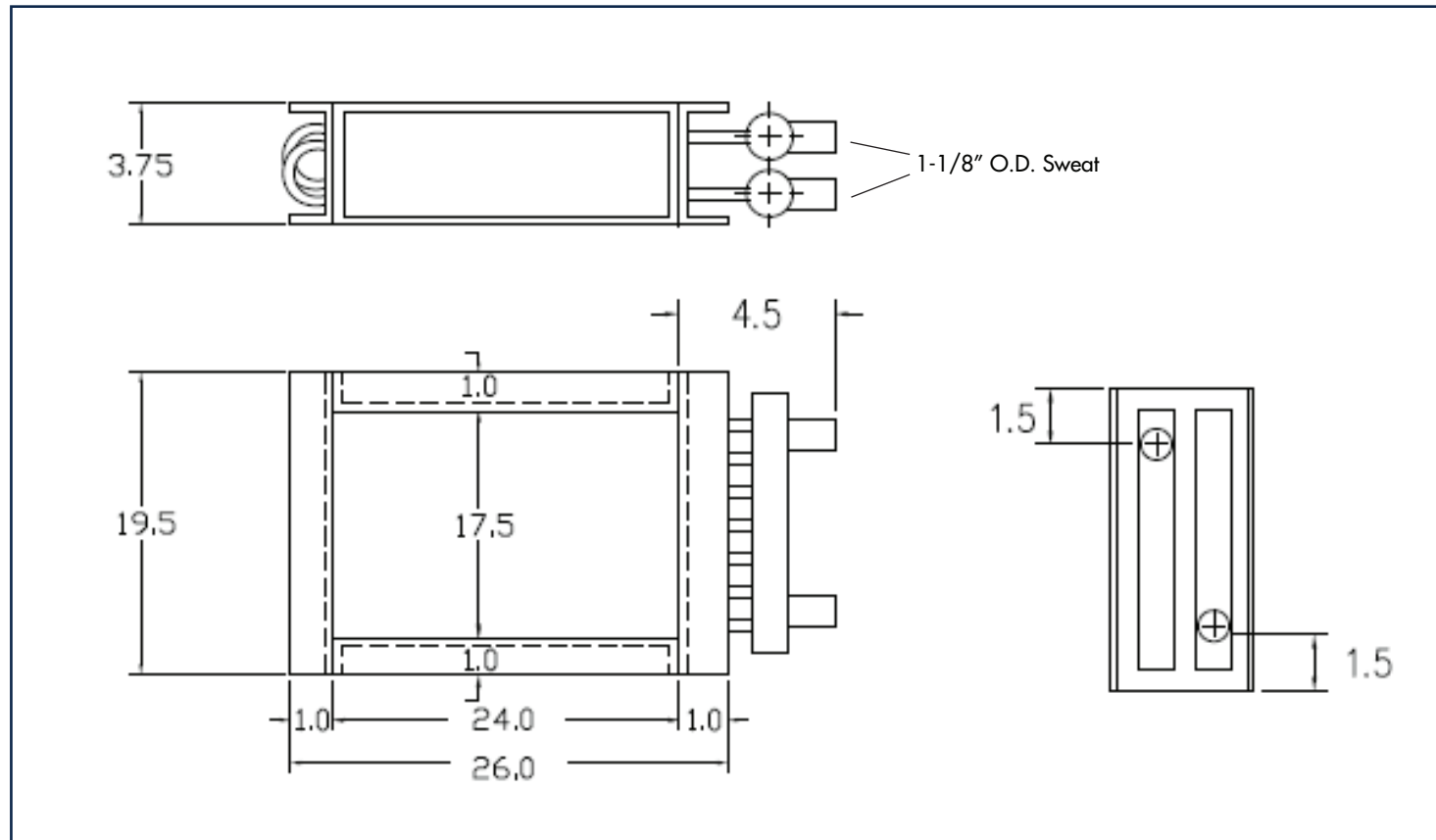

Model: NWC-1724-2				60°F Entering Air		
E.W.T.	GPM	P.D. FT	CFM	MBTUH	L.A.T. °F	L.W.T. °F
180°F	7.2	3.53	1500	79.8	109	157.3
			1700	85	106	155.8
			1900	89.6	103.5	154.5

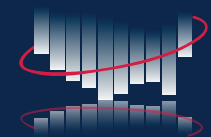

**NATIONWIDECOILS**

1-888-COIL-PRO  
www.nationwidecoils.com

# NWC-2020-2 Series

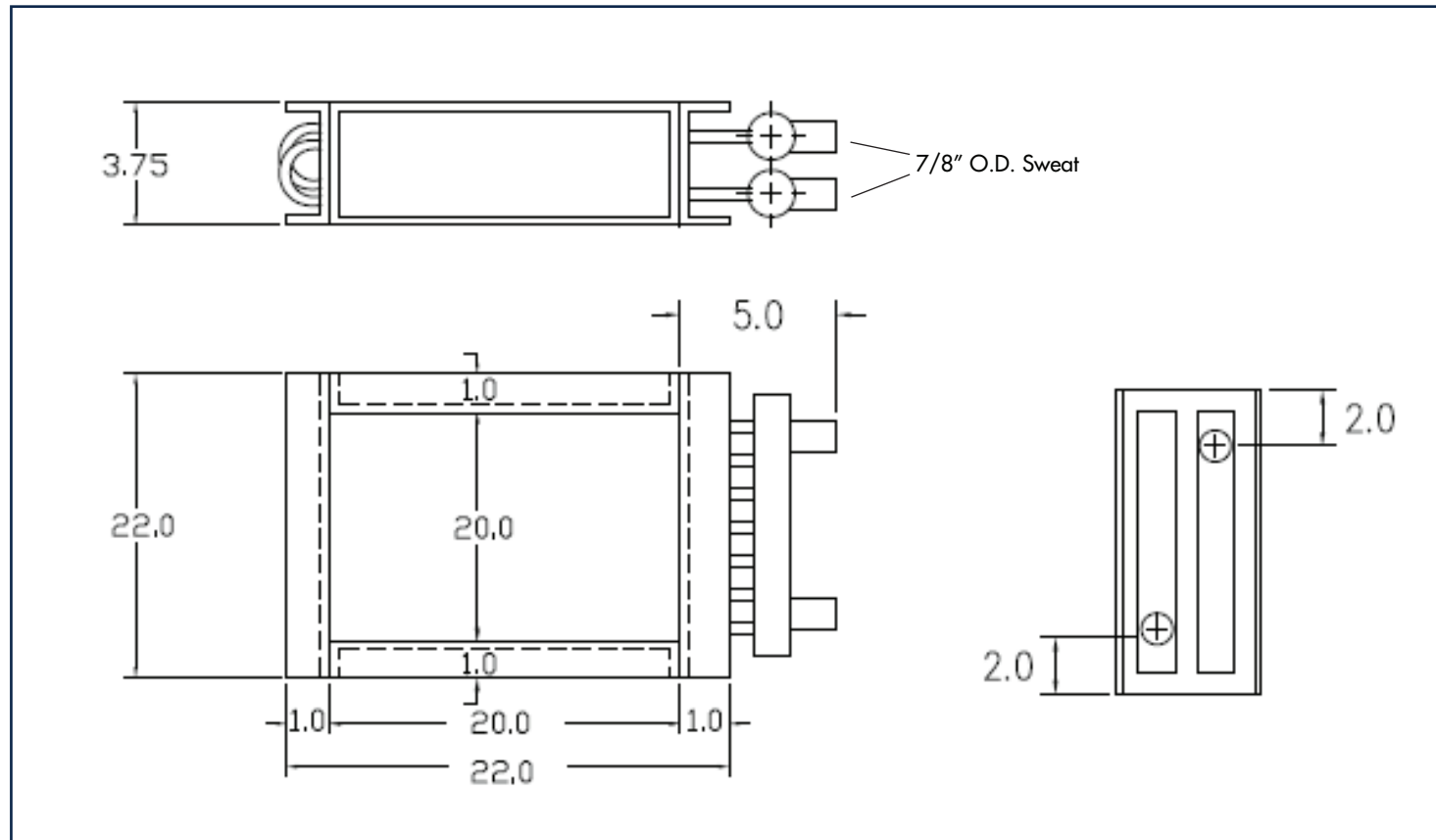

Model:NWC-2020-2				60°F Entering Air		
E.W.T.	GPM	P.D. FT	CFM	MBTUH	L.A.T. °F	L.W.T. °F
180°F	6.0	1.59	1000	58.6	114	160
			1500	71.3	103.9	155.6
			2000	80.6	97.2	152.5
	7.5	2.48	1000	60.8	116.1	163.4
			1500	74.7	106	159.6
			2000	85.1	99.3	156.7
	8.6	3.26	1000	62	117.2	165.2
			1500	76.6	107.1	161.7
			2000	87.6	100.4	159.1

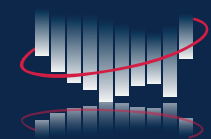

**NATIONWIDECOILS**

1-888-COIL-PRO  
www.nationwidecoils.com

# NWC-2025-2 Series

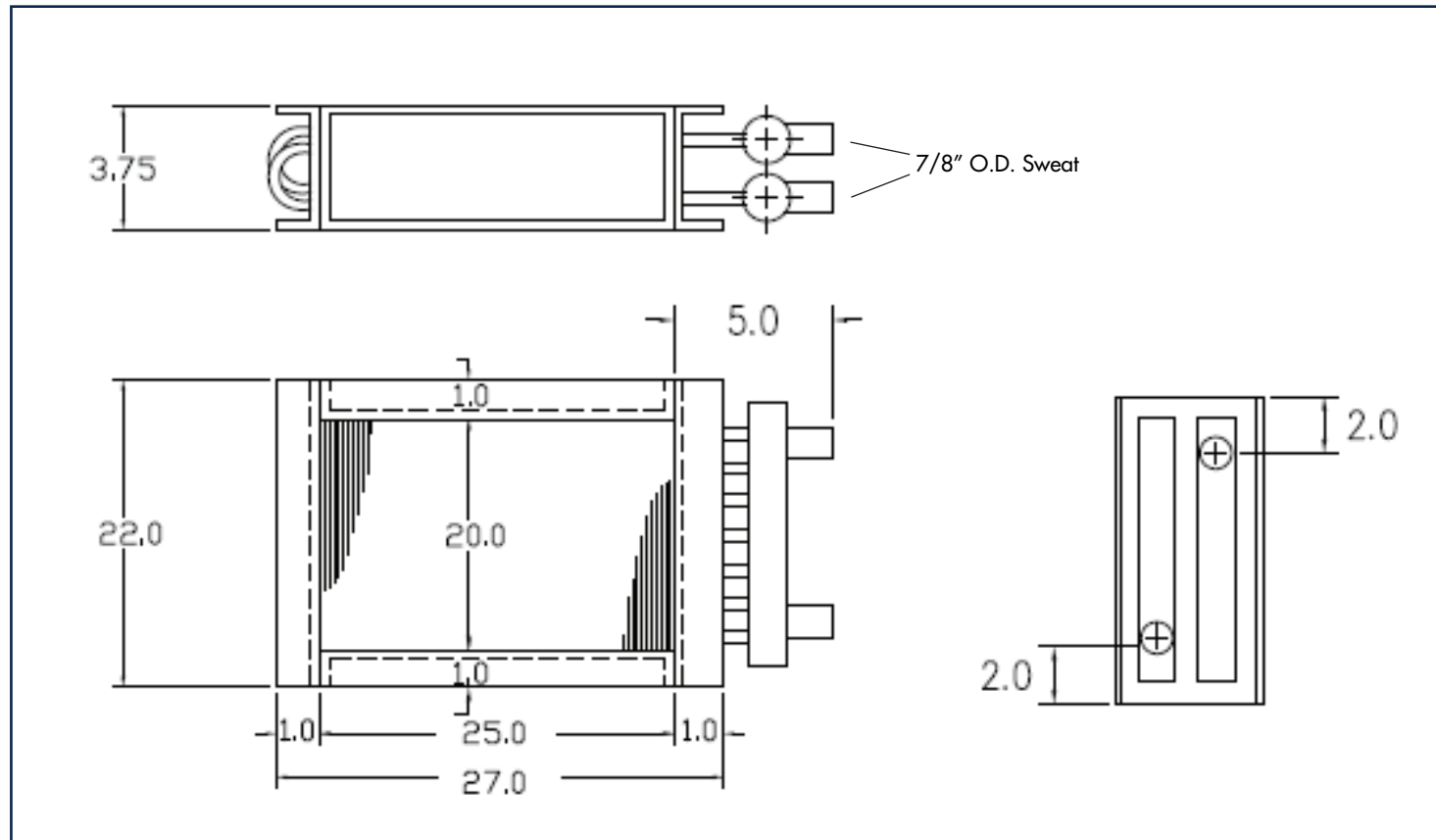

Model:NWC-2025-2				60°F Entering Air		
E.W.T.	GPM	P.D. FT	CFM	MBTUH	L.A.T. °F	L.W.T. °F
180°F	10	4.5	1500	86	112.9	162.3
			2000	99.5	105.9	159.6
			2500	110	100.7	157.4
	15	10.11	1500	90.68	115.7	167.6
			2000	105.84	108.8	165.5
			2500	118.27	103.6	163.8
	20	17.93	1500	93.2	117.3	170.4
			2000	109.38	110.4	168.8
			2500	122.73	105.3	167.4

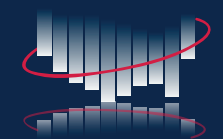

**NATIONWIDECOILS**

1-888-COIL-PRO  
www.nationwidecoils.com

# NWC-2025-3 Series

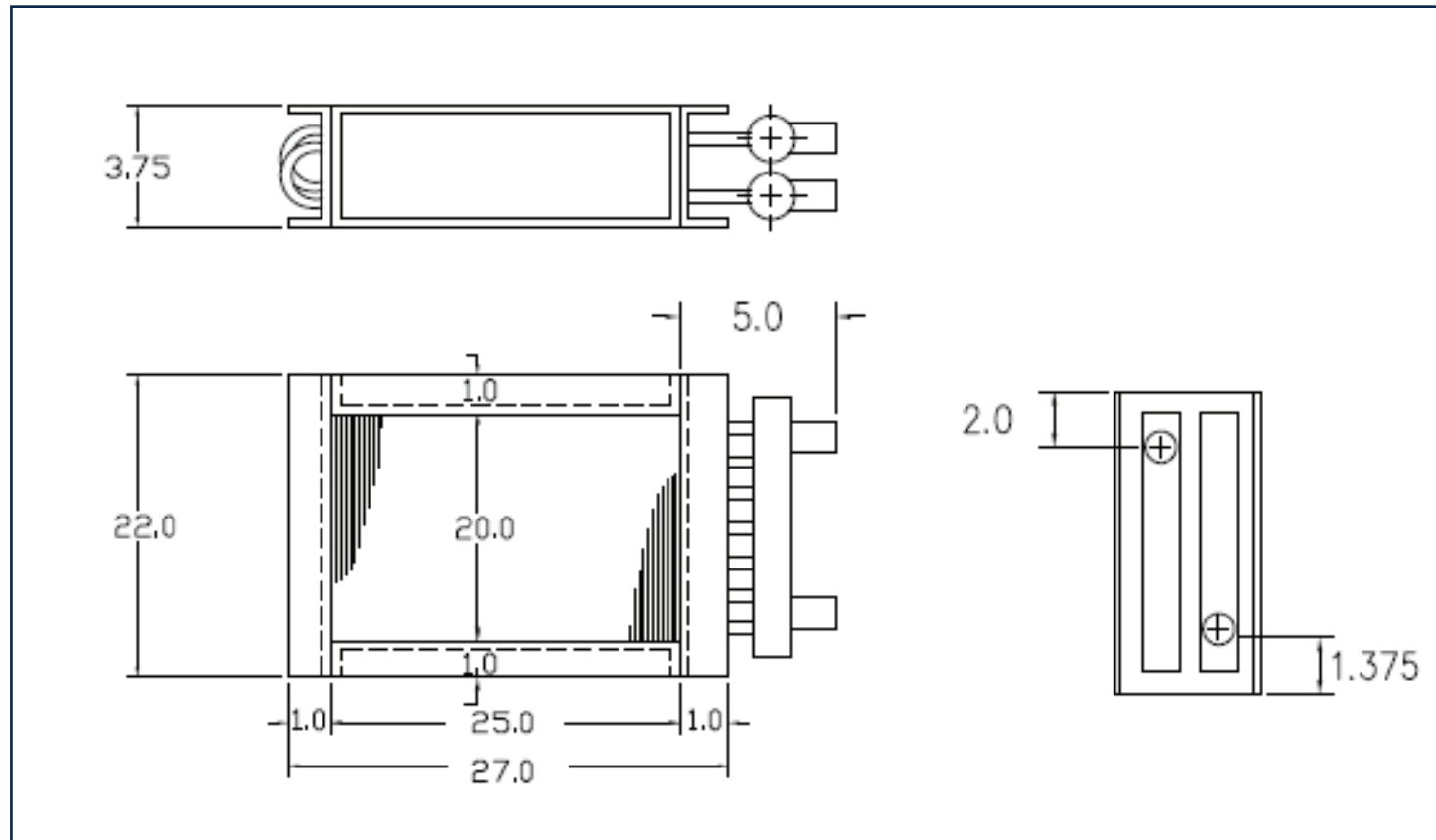

Model: NWC-2025-3				60°F Entering Air		
E.W.T.	GPM	P.D. FT	CFM	MBTUH	L.A.T. °F	L.W.T. °F
180°F	10	4.9	1500	112.67	129.3	156.9
			2000	131.96	120.8	153
			2500	147.46	114.4	149.8
	15	10.96	1500	118.2	132.7	163.8
			2000	140.08	124.6	160.8
			2500	158	118.3	158.4
	20	19.42	1500	121.18	134.5	167.6
			2000	144.5	126.6	165.2
			2500	163.96	120.5	163.2

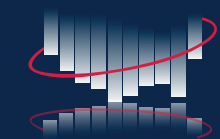

**NATIONWIDECOILS**

1-888-COIL-PRO  
www.nationwidecoils.com

# NWC-2525-2 Series

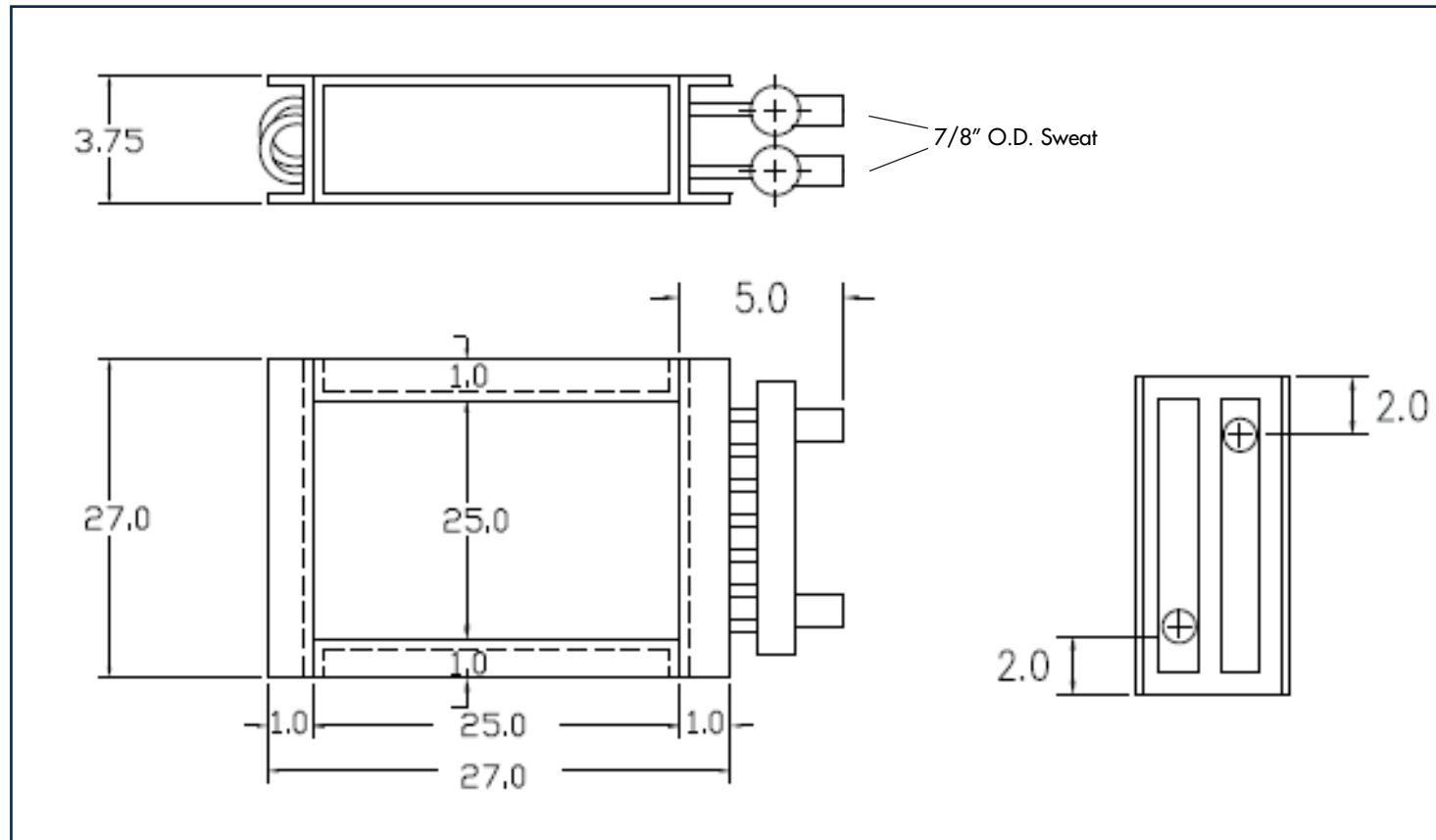

Model: NWC-2525-2				60°F Entering Air		
E.W.T.	GPM	P.D. FT	CFM	MBTUH	L.A.T. °F	L.W.T. °F
180°F	9.8	3.8	1800	101.1	111.8	158.8
			2400	116.4	104.7	155.6
			3000	128.6	99.5	153.1
	11.2	4.96	1800	103.5	113	161
			2400	119.5	105.9	158.1
			3000	132.4	100.7	155.8
	12.5	6.17	1800	105.2	133.9	162.7
			2400	121.9	106.9	160
			3000	135.4	101.6	157.8

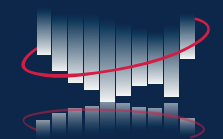

**NATIONWIDECOILS**

1-888-COIL-PRO  
www.nationwidecoils.com

# NWC-2030-2 Series

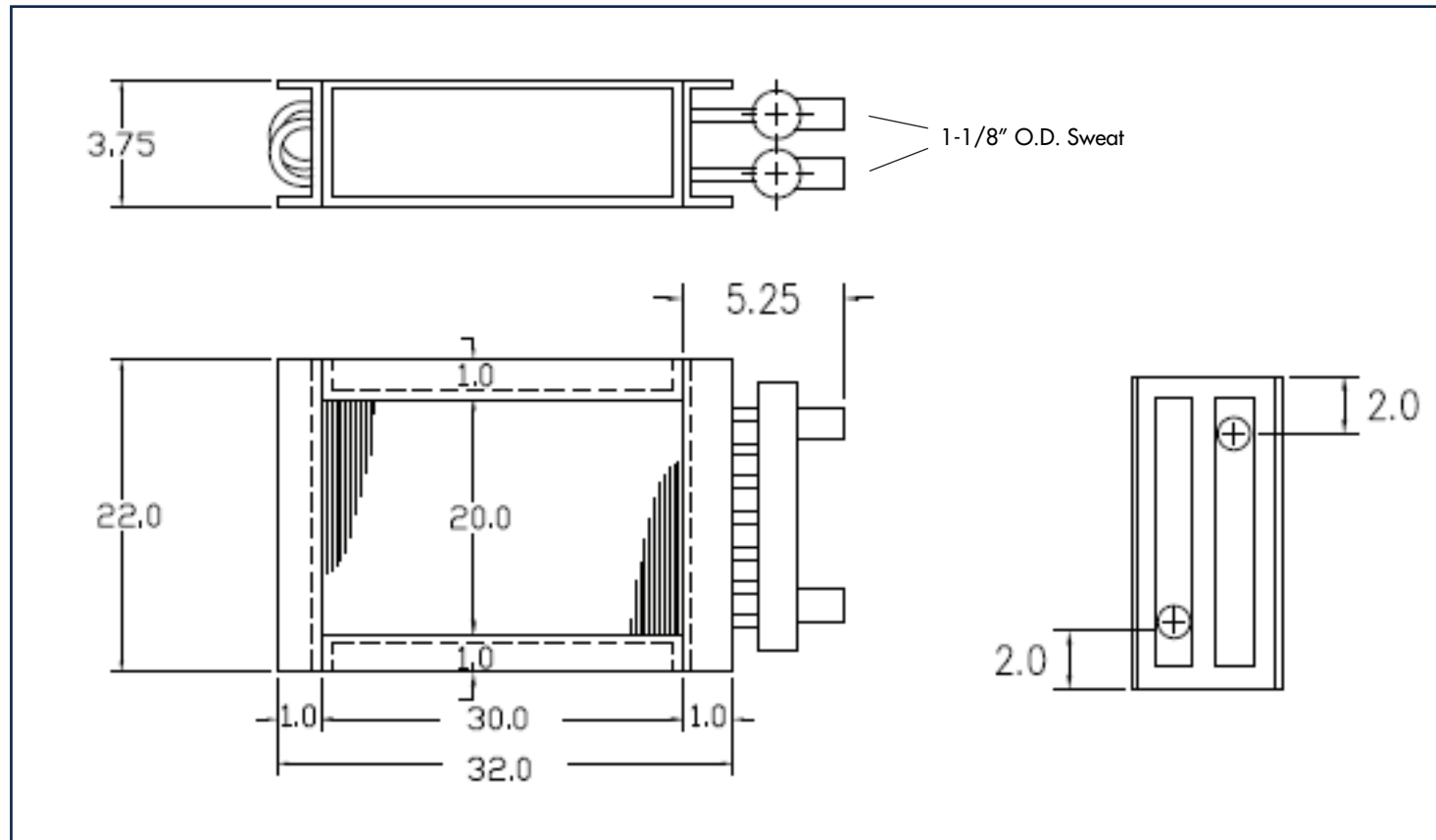

Model: NWC-2030-2				60°F Entering Air		
E.W.T.	GPM	P.D. FT	CFM	MBTUH	L.A.T. °F	L.W.T. °F
180°F	15	4.98	1800	107.64	115.1	165.3
			2400	125.38	108.2	162.8
			3000	139.87	103	160.9
	20	8.8	1800	110.96	116.8	168.6
			2400	129.97	109.9	166.7
			3000	145.65	104.8	165
	25	13.68	1800	113	117.9	170.7
			2400	132.92	111.1	169.1
			3000	149.4	105.9	167.7

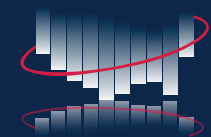

**NATIONWIDECOILS**

1-888-COIL-PRO  
www.nationwidecoils.com

# NWC-2030-3 Series

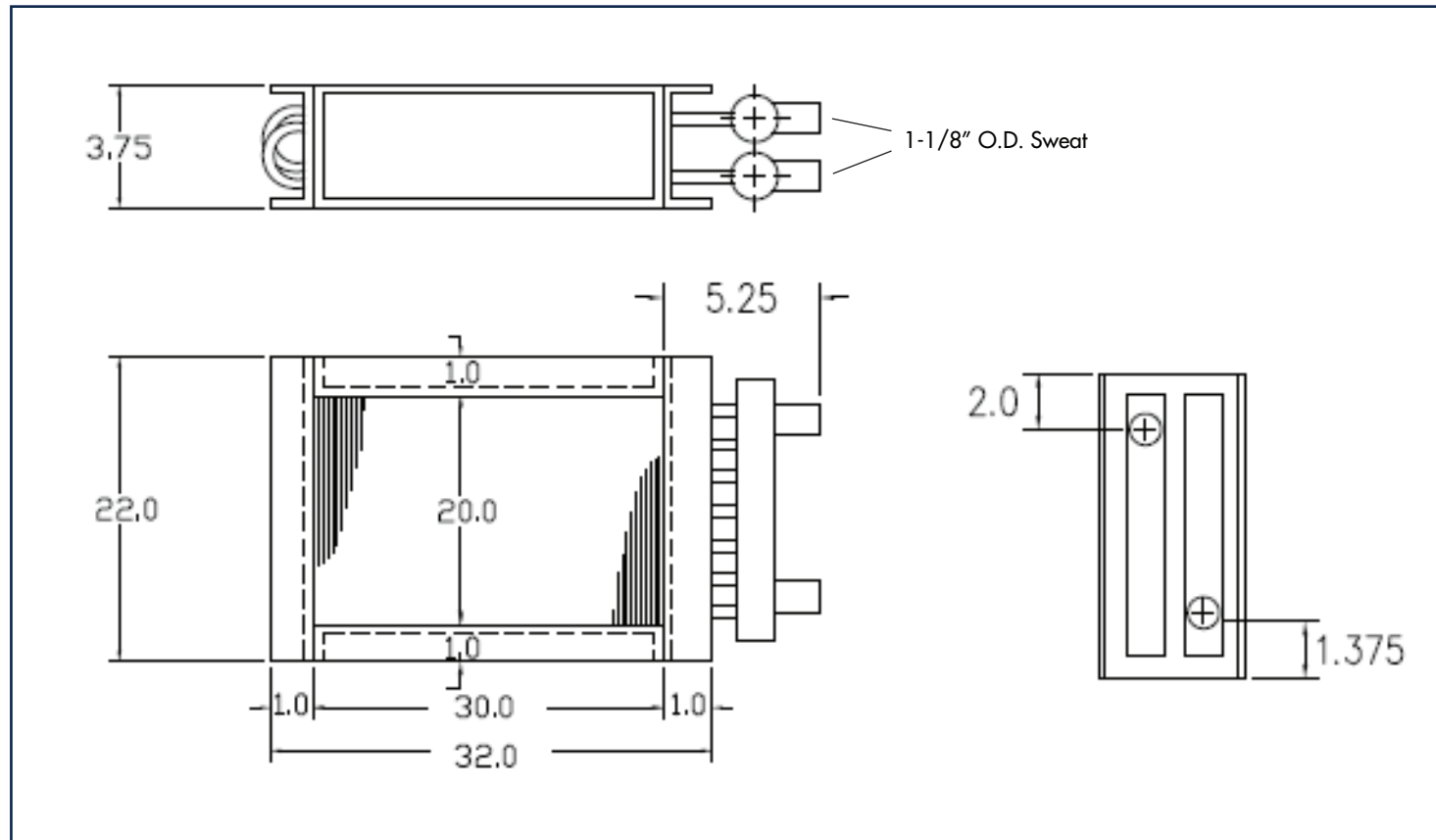

Model: NWC-2030-3				60°F Entering Air		
E.W.T.	GPM	P.D. FT	CFM	MBTUH	L.A.T. °F	L.W.T. °F
180°F	15	5.96	1800	140.39	131.9	160.8
			2400	165.88	123.7	157.3
			3000	186.73	117.4	154.5
	20	10.5	1800	144.3	133.9	165.2
			2400	171.7	126	162.4
			3000	194.43	119.8	160.1
	25	16.3	1800	146.74	135.2	167.9
			2400	175.38	127.4	165.6
			3000	199.35	121.3	163.6

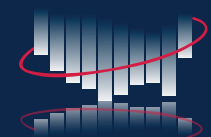

**NATIONWIDECOILS**

1-888-COIL-PRO  
www.nationwidecoils.com